



Maximum order picking performance

Medium level picker EPL 100

| | |
|--|---|
|  <p>AC tech</p> | <p>24/7 support</p> |
|  <p>worldwide network</p> |  <p>OP order pickers</p> |
| <p>EPL</p> | |





In any materials handling operation, we find the four basic handling functions; loading/unloading, horizontal transportation, stacking and order picking. All of which add to the cost and not the value of a product or service. The most labour intensive of all these is order picking. This also makes it the most expensive of all materials handling functions. In fact the cost of order picking can be up to ten times the cost of the other three handling operations added together.

Faster performance in the other three handling methods will have an impact on saving money, but maximising the performance of the picking operation will create the largest and most significant cost reduction. Design, rather than luck, is the key to achieving this. The physical act of order picking an item from a storage location and placing it on the load carrier is limited in terms of performance improvement. However, the location of the picking stock and getting the operator closer to that location are the two main factors that can have a tremendous influence on reducing order picking costs.

Pickers struggling to access a product waste time and your money. Pickers that gain quick and easy access to a pick location get the job done efficiently. They make better use of the time available to them, thereby significantly helping to reduce costs.

The ATLET by UniCarriers EPL truck is designed to provide quick, ergonomic and cost-effective order picking. The EPL is a medium level order picking truck available in two basic configurations to facilitate order picking either from racking or shelving systems.

The ATLET by UniCarriers EPL 100 allows easy order picking from a height of 2800 mm to 3400 mm.

By providing the operator with immediate free access to pick locations, the EPL reduces the time required for order picking, thereby cutting costs and increasing profitability.



UniCarriers designs, manufactures and supports the most advanced material handling equipment. By integrating the three distinctive brands of Atlet, Nissan Forklift and TCM, UniCarriers is the perfect mixture of Japanese quality and technology as well as Swedish design and ergonomics. UniCarriers represents more than 65 years of industry experience, an unparalleled global reach and deep understanding of local markets.

UniCarriers Europe intro

EPL 100 medium level order picker

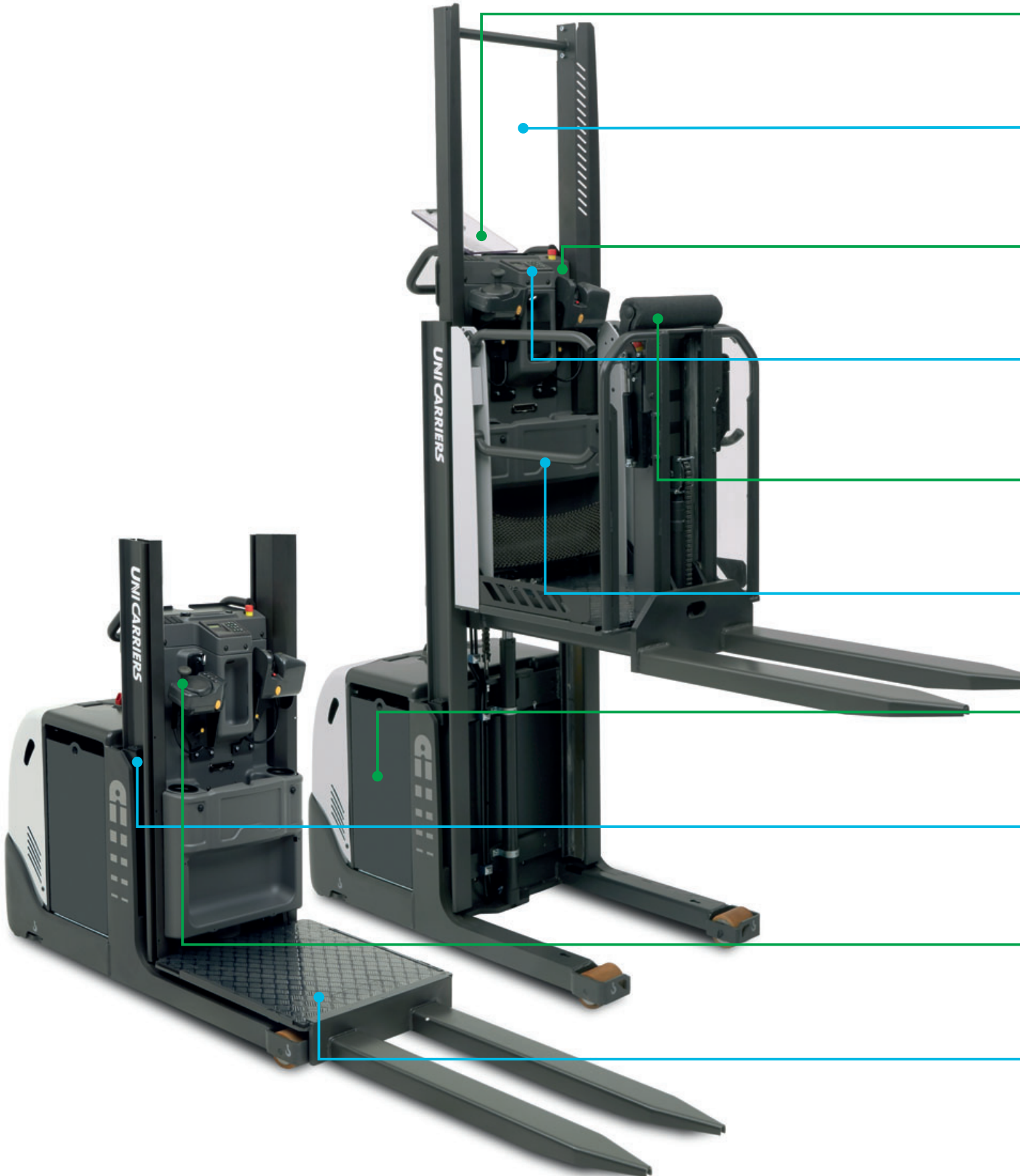

duces

ProVision over head guard and mast concept for maximum visibility and safe driving.



Writing desk to improve efficiency in picking administration.



Driver access by PIN code to limit use only to authorised operators and to upload individual driver profiles.



Controls integrated into chassis creates a shorter, more manoeuvrable truck plus extra working room on the platform.



Pro-Access side gates with automatic sensors to prevent use of the truck with gates open when above 1200 mm.



Fully adjustable lean on option for improved comfort levels.



Walk beside button to aid quicker picking from two adjacent locations.



Quick and easy battery access. For daily maintenance or for battery changing in multi-shift operations.



Low step in reduces fatigue and improves performance. An automatic floor sensor establishes driver presence and engages stop mode upon departure.



Adjustable position of controls allows operators to adapt the truck to suit their individual comfort levels.

High-speed option (12 km/h) for enhanced performance.



| Model | EPL 100 | |
|---------------------------------|---|------------------|
| Platform lift height | 1200 mm | 1800 mm |
| Picking height | 2800 mm | 3400 mm |
| Lift capacity | 1000 kg | |
| Truck width | 810 mm | |
| Lowered platform step in height | 160 mm | |
| Drive speed | Standard 9 km/h with high speed option of 12 km/h | |
| Standard equipment | Battery on steel rollers for easy battery change | |
| | OnBoard truck computer with PIN code access | |
| | Chill store specified | |
| | Selectable ECO driving mode | |
| | | Ergo lift |
| | | Pro-Access gates |
| Extra equipment | Ergo lift | |
| | Side gates | |
| | Walk-beside controls | |
| | Vehicle and operator management system | |
| | Cold store specification | |
| | Overhead guard | |
| | Writing desk | |
| | Equipment bar | |
| | 12 volt power outlet | |

It's all about
the price.
**But what
price?**

Reduce your Total Cost of Operation with UniCarriers

We agree. Price is everything. Or to be more specific: your Total Cost of Operation (TCO). That's why we're so focused on cutting costs and improving your material handling. The truck and its performance play an important role, but this is even more about how we can support you in optimising your warehouse operations to give you the best value for your money. Which – in the long run – is what creates a winner.